



Dixie Canner Company

786 East Broad Street, Athens, Georgia 30601 USA
706-549-1914 706-549-0137 FAX
sales@dixiecanner.com • www.dixiecanner.com

Worldwide Dependability — Can Packaging & Processing Equipment

OPERATOR'S MANUAL Model 23H Hand Crank Seamer

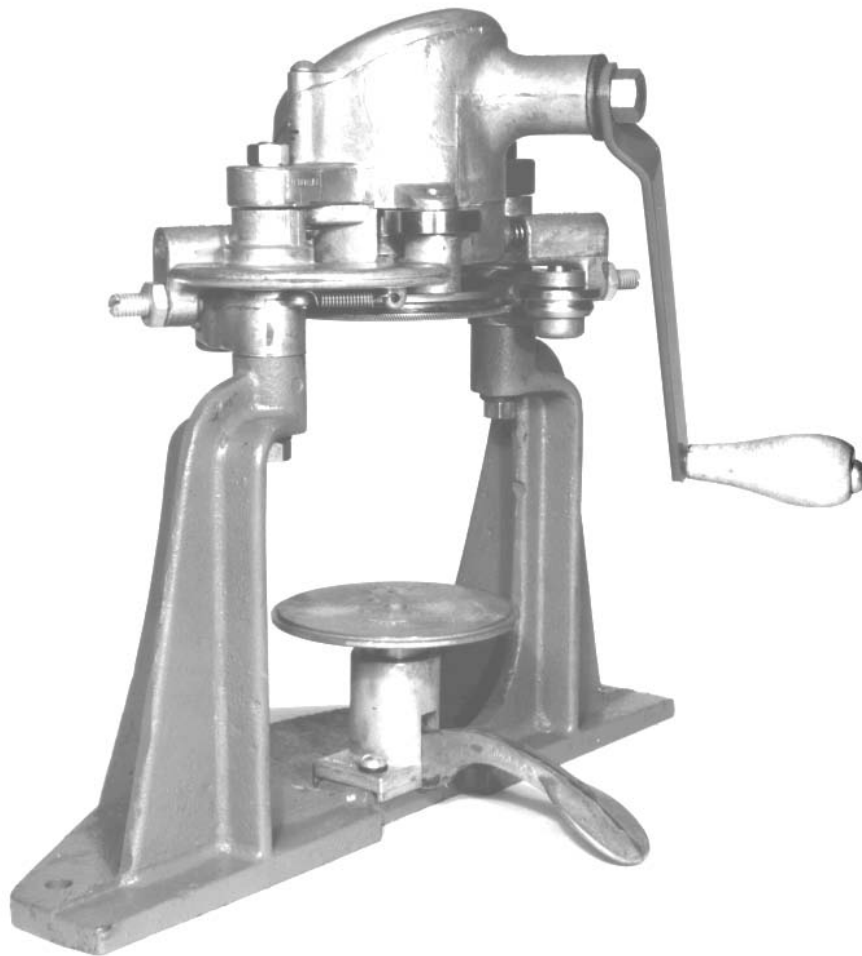

If you are not experienced with your seamer, please read and understand this manual before operating the machine. If you have a question discuss it with your supervisor or contact Dixie Canner Company.

INTRODUCTION

The Dixie Model 23H Hand Crank Seamer, shown on the front cover, brings together in compact form, the valuable features of larger, more expensive, power driven machines. The Model 23H Hand Crank Seamer is adaptable for containers up to 4¼" diameter and 5" tall. At time of fabrication, extension posts may be used to accommodate containers taller than 5 inches.

INSTALLATION

1. Attach seamer firmly to table or bench.
2. Turn hand crank until indicating line on cam roll lever [21] is directly in line with arrow located just above on gear housing [3]. The seaming rolls will then be in their neutral or outermost position in relation to the seaming chuck.

OPERATION

With base plate in lower position, place filled can with top in place on the baseplate. Lower the can raising lever [23] to raise can into position with the chuck. Turn the hand crank twenty (20) turns in the direction indicated by the arrow. Raise the can raising lever, remove the can and repeat the operation for the next can.

CHANGING FROM ONE SIZE CAN TO ANOTHER:

Change parts consisting of a chuck, a base plate and a height spacer may be required for each different can diameter, top or style. Also, a different set of seaming rolls may be required for each. Your can manufacturer

or supplier may recommend the seam roll profiles for your cans. Dixie stocks or may be able to furnish the seam roll profile needed. Make sure you have the correct change parts available when changing your machine from one can size to another, then proceed as follows:

1. Turn hand crank until seam rolls assume their neutral position. (Indicating line on cam roll lever is directly in line with arrow just above gear housing.)
2. Remove screw for housing cover and lift off cover to expose upper end of chuck shaft [14-1].
3. Loosen lock nuts [16] and loosen set screws [17] until both seam roll levers [12] are back as far as they will go. If needed, change seaming rolls.
4. Change chucks. CAUTION: To prevent damage to the chuck shaft and/or internal gears, use an open end wrench to hold the chuck shaft (remove the housing cover [1] for access) while loosening or tightening the chuck.

To remove the chuck, hold the chuck shaft [14-1] with a wrench on the top of the shaft, located under the gear housing cover. Then place the two pins of the chuck wrench [44], provided with your seamer, into two of the four holes located on the bottom of the chuck. (The pins of the chuck wrench will fit into either diagonal or adjacent holes depending on the diameter of the chuck.) To loosen, turn the chuck to the left. Finish removing the chuck by hand.

To install a new chuck, hold the chuck shaft with a wrench, as described above, while using your hand to thread the chuck onto the lower end of the chuck shaft. Turn to the right to thread the chuck onto the

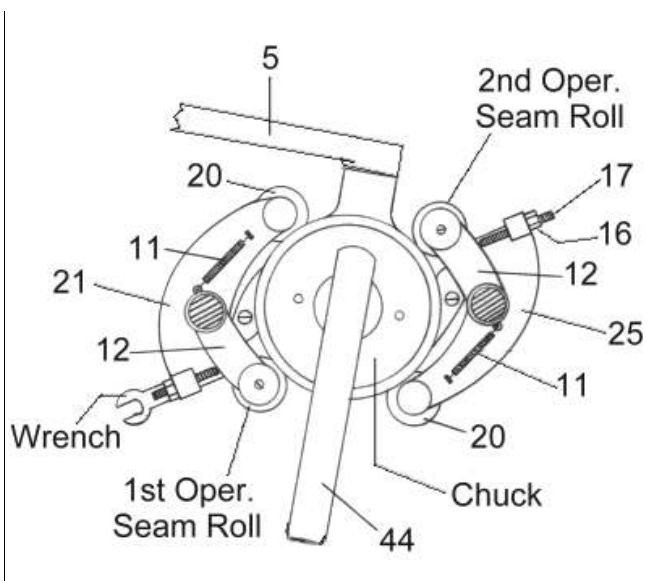

Bottom View Showing Chuck

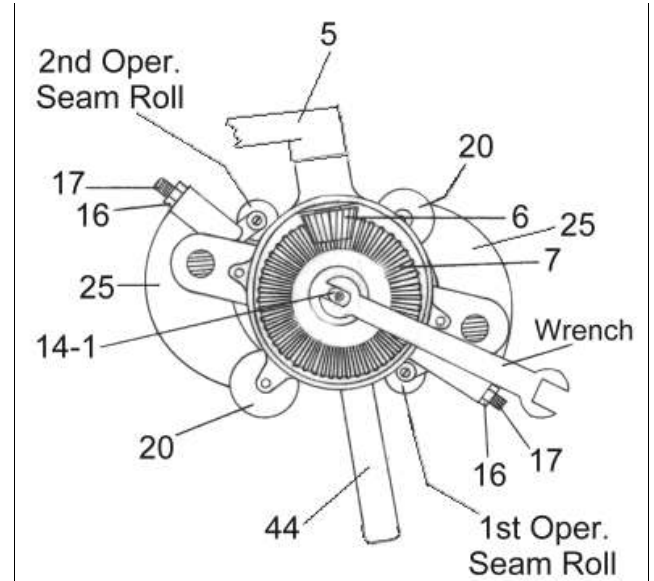

Top View with Housing Cover Removed

chuck shaft. Use the chuck wrench, as described above, to tighten snugly. Make certain that the new chuck is properly tightened into position against the shoulder of the chuck shaft.

5. Replace gear housing cover [1].
6. Install the proper base plate for the can to be closed. Adjust the base pressure and seam rolls as outlined on the following page.

NEUTRAL POSITION

The machine is in a neutral position when both cam rolls [20] are in their innermost position and both seaming rolls are in their outermost position. The indicating line on cam roll lever should be directly in line with arrow just above gear housing.

SEAMING ROLL ADJUSTMENTS:

There are twenty (20) revolutions per seaming cycle, ten (10) for each seaming roll. The function of the first operation seam roll is to curl the cover hook and body hook into proper position. The function of the second operation seam roll is to complete the sealing of the can.

FIRST OPERATION

1. Put machine in neutral position by positioning the cam roll lever [21] directly in line with arrow on gear housing and hand crank in downward position.
2. Make nine (9) turns of the hand crank in the direction indicated by the arrow. This will bring the first operation seam roll to its innermost position in relation to the chuck.
3. Loosen lock nut [16] and adjust set screw [17] until the first operation seam roll is snugly in position with the chuck. While holding the first operation (larger) gauge wire [40] in position between the chuck lip and the ground profile of the first operation seam roll, tighten the lock nut. **DO NOT PLACE WIRE IN GROOVE OF SEAMING CHUCK.** The larger diameter gauge wire [40] is the approximate **THICKNESS** of the first operation seam. Final adjustments may be made after a can is closed and the double seam inspected.
4. Tighten lock nut [16]. Use screwdriver to keep screw [17] from turning when tightening the lock nut.

SECOND OPERATION

1. After adjusting first operation roll, give hand crank exactly nine (9) turns in the direction indicated by

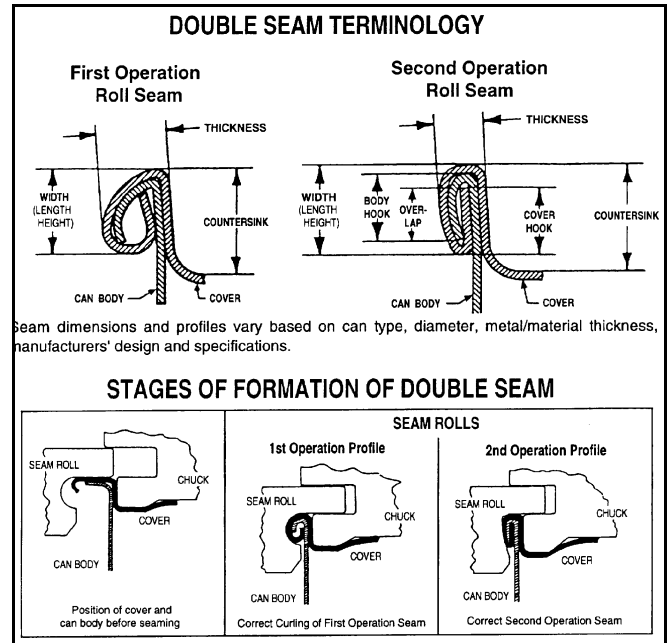

- arrow. This is equivalent to eighteen turns from neutral or starting position and brings the second operation seam roll to its innermost position in relation to the chuck.
2. Loosen lock nut [16]. Place the second operation (smaller) gauge wire [41] in the groove of the second operation seam roll and adjust the screw [17] until the gauge wire fits snugly between the roll and the roughened or knurled edge of the chuck. Move gauge wire back and forth to allow sufficient friction to turn seam roll. **DO NOT PLACE WIRE IN GROOVE OF SEAMING CHUCK.** The small diameter gauge wire [41] represents the approximate **THICKNESS** of the second roll seam. Final adjustments may be made after a can is closed and the double seam inspected.
3. Tighten lock nut [16]. Use screwdriver to keep screw [17] from turning when tightening the lock nut.
4. Turn hand crank two more turns to place seamer in neutral again.
5. Close a can, tear down and inspect the double seam. Make final adjustments of the seaming rolls and base plate pressure to produce essential body hook, cover hook, overlap and tightness recommended by the container manufacturer or for a hermetically sealed can. **NOTE:** If you are unable to obtain the essential measurements recommended or a hermetically seamed container, you may need seam rolls with different profiles.

NOTE: When adjusting seam rolls, make sure you start from neutral position. Count carefully number of turns of crank. Be sure seam roll is in its inner-most position

when inserting gauge wire. Also make certain to place the gauge wire in the groove of the seam roll, NOT in the groove of the chuck.

If your seamer shows a tendency to work overly hard, or “lock,” check adjustments of the seam rolls. CAUTION: To avoid damage to your seamer, make sure that the seam roll is no closer to the chuck than to allow the small gauge wire to pass.

BASE PLATE PRESSURE ADJUSTMENTS

Proper base plate pressure is required to produce essential body hook and prevent slipping of can during the seaming cycle. Each base plate has an adjusting screw [57] and set screw [56] in its stem for making minute base plate adjustments as follows:

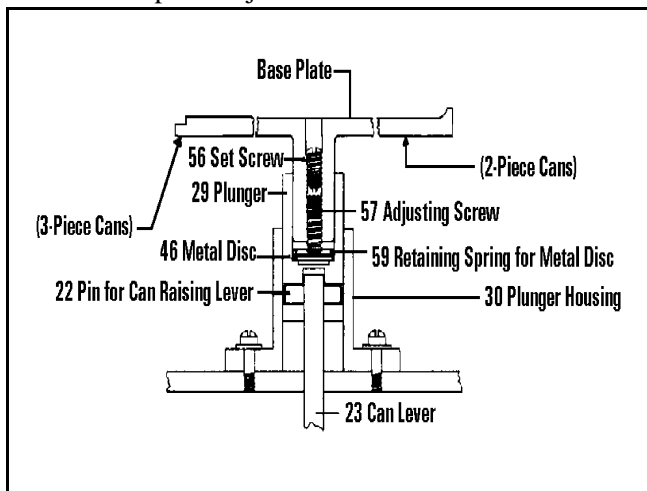

SECTIONAL VIEW OF BASE PLATE ASSEMBLY

1. Lift base plate out of plunger [29] and inspect the metal discs [46]. Replace metal discs if there is any sign of undue wear or breakage. To replace the metal discs, first remove the plunger housing [30] and disassemble. Through the hole in the bottom of the plunger [29], insert a nail or punch and knock out the metal discs [46] and retainer spring [59]. Replace with new discs and reassemble, making certain that the retainer spring and metal discs are properly seated and that the entire assembly is adequately lubricated (oiled).
2. Insert screwdriver in the hole in the top of the base plate and loosen set screw [56] by turning counter clockwise.
3. Turn adjusting screw [57] in the proper direction to lengthen or shorten effective height of the base plate, as may be required for proper tension (pressure). If you find it necessary to use pliers to turn the adjusting screw, be very careful not to damage threads.

4. Tighten set screw snugly. It may be necessary to hold the end of the adjusting screw firmly while tightening the set screw.
5. Make certain that the base plate assembly is properly lubricated and replace the base plate in the plunger.

TESTING THE DOUBLE SEAM

Before sealing a large number of cans or when changing from one size to another, ordinary precaution must be used to determine that the seamer is in proper adjustment and a satisfactory seam has been achieved. Can seam inspection should be performed routinely to ensure the seamer is in proper adjustment.

Seal a test can and inspect the double seam for droops, vees, tightness or other possible defects. If your can manufacturer has provided you with seam specifications, take measurements of the seam to be sure your seam is within recommended tolerances. Dixie offers a Can Seam Test Kit that will enable you to measure different aspects of the double seam.

If you are testing only for an airtight or hermetic seal, various “rule-of-thumb” methods may be used such as immersion in water to check for air bubbles which may indicate leakage. Please check with your supervisor to determine the seam test method that is proper for your purposes.

Refer to instructions for adjusting seam rolls and changing from one size can to another to readjust your seamer as necessary to obtain a correct double seam.

MAINTENANCE OF SEAMER

With ordinary care, your Dixie seamer should give you excellent trouble free service if the following simple rules are observed.

1. Keep the seamer in proper adjustment at all times.
2. Replace worn parts as needed.
3. Clean thoroughly after each daily use.
4. Apply a few drops of lightweight oil to all moving parts and in all holes plainly marked “OIL.” At the start of each season and periodically thereafter, remove housing cover [1] and apply grease to gears [6] and [7]. Use fitting on gear housing cover to lubricate (grease) chuck shaft. Use fitting on gear housing [3] to lubricate drive shaft [4].

CHANGE PARTS AND REPAIR PARTS

When ordering parts, always furnish both the part number and the name of the part. When ordering change parts for cans, always send six (6) loose tops and can bodies of the size can(s) to be closed.

REPAIR PARTS AND REBUILDING SERVICE

A complete stock of parts is maintained by Dixie Canner Company. Parts may be ordered as needed to replace worn or damaged parts.

Your Dixie Double Seamer may be returned to Athens, Georgia for complete rebuilding at a nominal service charge, plus the cost of parts needed. When returning the machine for the rebuilding service, please observe the following:

1. Return the complete machine and include several cans and tops of the exact size and type closed. Properly crate the machine and cans for safe delivery and return shipment, and prepay the shipping cost.
2. Write a letter authorizing the rebuilding service and mention any problem with the machine. Also mention particular instructions concerning return shipment, urgency, and other pertinent instructions.

HELPFUL HINTS — TROUBLESHOOTING

Until the operator is familiar with the mechanics of the seamer and learns to recognize irregularities in the essential requirements of the double seam, the outline below is intended to help notice obvious defects and list some causes that may serve as a guide in correcting minor troubles.

MECHANICAL DEFECTS & COMMON CAUSES

- A. Can slips during seaming operation.
 1. Damage or lack of oil in the base plate, lift shaft, or height spacer.
 2. Insufficient base plate pressure.
 3. Worn or broken metal discs in base plate seat. Remove base plate from plunger and check metal discs [46]. Replace discs if broken or excessively worn.
 4. Worn or wrong size chuck. Make sure that the lid fits properly against the chuck; the lid should fit snugly but should not bind. Dixie chucks are custom fabricated to fit the specific end which you submitted when the chuck was ordered. If you have changed lid styles, you may need a new chuck.
 5. Seaming rolls binding on screws.
- B. Machine operates with undue noise or "locks."
 1. Machine not properly timed.
 2. Broken drive shaft bevel gear. Remove gear housing cover [1] and check drive shaft bevel gear [6]; if broken, replace as follows:
 - a. With machine in neutral position and without turning hand crank, remove cotter key [100], then push drive shaft [4] back toward crank and replace gear. (If hand crank turns during this replacement, timing will be thrown off, making it impossible to adjust seaming rolls.)
 - b. Reposition drive shaft [4]; insert cotter key [100], then replace housing cover.

- C. Unusually loose seaming rolls.
 1. Seaming rolls or seam roll screws worn. Seam rolls should turn freely but without up and down movement or wobble. If undue wear is evident, replace with new screws and/or seam rolls.
- D. Seaming rolls do not return to neutral position.
 1. Seaming roll levers binding.
 2. Seaming lever spring weak or broken.
 3. Machine not properly timed.
- E. Machine seems to "labor" or freeze tight.
 1. Needs oil.
 2. Too much base plate pressure.
 3. Seaming rolls too tight.
 4. Misalignment of moving parts.

DOUBLE SEAM DEFECTS & COMMON CAUSES

- A. Cut over. Unusually sharp edge at top inside edge of seam.
 1. 1st or 2nd operation seam roll set too tight.
 2. Worn seam rolls or worn chuck.
- B. Cut or fractured seam.
 1. Seam rolls set too tight.
- C. Droop or lap in double seam at or near can body side seam.
 1. Too much base pressure.
 2. 1st operation seam roll set too loose.
 3. Worn 1st operation seam roll.
- D. Excessive countersink depth.
 1. Too much base pressure.
 2. 1st operation seam roll set too loose.
 3. Chuck not properly seated in can top.
 4. Chuck groove worn.
- E. False seam. Body hook and cover hook do not overlap.
 1. Can top not properly seated on can.
 2. Damaged can flange or can top curl.
- F. Long body hook.
 1. Too much base pressure.
- G. Long cover hook.
 1. 1st operation seam roll set too tight.
- H. Short body hook.
 1. Insufficient base pressure.
 2. 1st operation seam roll set too tight.
 3. 2nd operation seam roll set too loose.
- I. Short cover hook.
 1. Too much base pressure.
 2. 1st operation seam roll set too loose.
 3. Worn 1st operation seam roll.
 4. Excessive countersink depth.
- J. Cover hook or body hook not uniform.
 1. Base plate or plunger worn.
 2. Chuck or seam rolls out of alignment.
- K. Droops, vees, wrinkles.
 1. Excessive base pressure.
 2. 1st operation seam roll too loose or worn.
 3. 2nd operation seam roll too tight.
 4. Defects in can body or top.
 5. Incorrect seam roll profiles.

